

A Refined Scooter Control Solution

The new **R-series 50** means a refined drive experience, blending innovative performance improvements with an unprecedented balance of power and size.

Performance Features:

- 50 Amps of power when you need it.
- Improved motor matching algorithms for improved curb-climbing and hill-starting capabilities.
- Dynamic's unique Speed Reduction Wiper (SRW) provides improved safety by increasing stability and control when turning.
- Drop in replacement with industry standard connections and mounting support.
- Programmable acceleration curves, zero roll back on slopes.
- 2 drive profiles, brake and reverse lights, reversing beeper and electronic park brake release.
- Intelligent motor and battery management features provide automatic power flow optimisation.
- Advanced diagnostics to provide indepth logging and analysis of battery performance / abuse.
- A Smart Servicing Scheduler calculates and indicates when servicing is due.

R-series 50

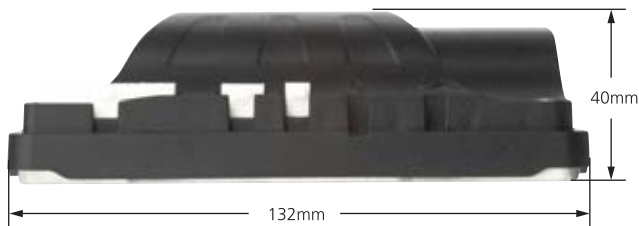

Physical Specifications:

Supply Voltage	24V DC
Operating Voltage	18–32V DC
Peak Current	40 Amps
Boost Current	10 Amps
Boost Duration	1–10 seconds
Brake Voltage	24V DC
Charging Current	8 Amps RMS

Protection Rating	Electronics to IPx5
Operating Temperature	-25°C to 50°C
Storage Temperature	-40°C to 65°C
Materials	Die-cast aluminium base with polymer cover (UL94 V-0 rating)
Part Numbers	DR50-A01

Corporate Office New Zealand
Ph: +64-3-962-2519
Fax: +64-3-962-2966
Email: info@dynamiccontrols.com

USA
Ph: +1-440-979-0657
Fax: +1-440-979-1028
Email: usa@dynamiccontrols.com

Asia
Ph: +886-955-335-243
Fax: +886 225-981-562
Email: asia@dynamiccontrols.com

Europe
Ph: +44-1905-772-321
Fax: +44-1905-827-520
Email: europe@dynamiccontrols.com



dynamic™ 

Dynamic Controls is the world's leading manufacturer of electronic controls for power wheelchairs and scooters. Dynamic was established in 1972 and is headquartered in New Zealand. Regional centres are located in Europe, United States, Asia, and Australasia. ISO 13485 accredited – Dynamic goes above and beyond industry standard expectations to ensure customers receive the best products possible.

For more information about Dynamic Controls visit www.dynamiccontrols.com

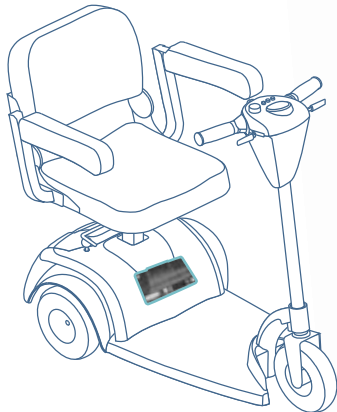

A Refined Scooter Control Solution

The new **R-series 90** means a refined drive experience, blending innovative performance improvements with an unprecedented balance of power and size.

Performance Features:

- 90 Amps of power when you need it.
- Improved motor matching algorithms for improved curb-climbing and hill-starting capabilities.
- Dynamic's unique Speed Reduction Wiper (SRW) provides improved safety by increasing stability and control when turning.
- Drop in replacement with industry standard connections and mounting support.
- Programmable acceleration curves, zero roll back on slopes.
- 2 drive profiles, brake and reverse lights, reversing beeper and electronic park brake release.
- Intelligent motor and battery management features provide automatic power flow optimisation.
- Advanced diagnostics to provide indepth logging and analysis of battery performance / abuse.
- A Smart Servicing Scheduler calculates and indicates when servicing is due.

R-series 90



Physical Specifications:

Supply Voltage	24V DC
Operating Voltage	18–32V DC
Peak Current	70 Amps
Boost Current	20 Amps
Boost Duration	1–10 seconds
Brake Voltage	24V DC
Charging Current	8 Amps RMS

Protection Rating	Electronics to IPx5
Operating Temperature	-25°C to 50°C
Storage Temperature	-40°C to 65°C
Materials	Die-cast aluminium base with polymer cover (UL94 V-0 rating)
Part Numbers	DR90-A01

Corporate Office New Zealand
Ph: +64-3-962-2519
Fax: +64-3-962-2966
Email: info@dynamiccontrols.com

USA
Ph: +1-440-979-0657
Fax: +1-440-979-1028
Email: usa@dynamiccontrols.com

Asia
Ph: +886-955-335-243
Fax: +886 225-981-562
Email: asia@dynamiccontrols.com

Europe
Ph: +44-1905-772-321
Fax: +44-1905-827-520
Email: europe@dynamiccontrols.com



dynamic™

Dynamic Controls is the world's leading manufacturer of electronic controls for power wheelchairs and scooters. Dynamic was established in 1972 and is headquartered in New Zealand. Regional centres are located in Europe, United States, Asia, and Australasia. ISO 13485 accredited – Dynamic goes above and beyond industry standard expectations to ensure customers receive the best products possible.

For more information about Dynamic Controls visit www.dynamiccontrols.com